

# raise-d<sup>3</sup>

prints that matter!

## Inhaltsverzeichnis

1. Einfuehrung.....	2
1.1. Sicherheitshinweise.....	2
1.2. Lieferumfang.....	2
1.3. Technische Details.....	2
2. Montage des Druckers.....	3
2.1. Herstellen des Rahmens.....	3
2.2 Nachbearbeitung der Platten.....	3
2.3 Herstellen der Druckteile.....	3
2.4. Zusammensetzen des Rahmens.....	4
2.5 Lage der Komponenten.....	5

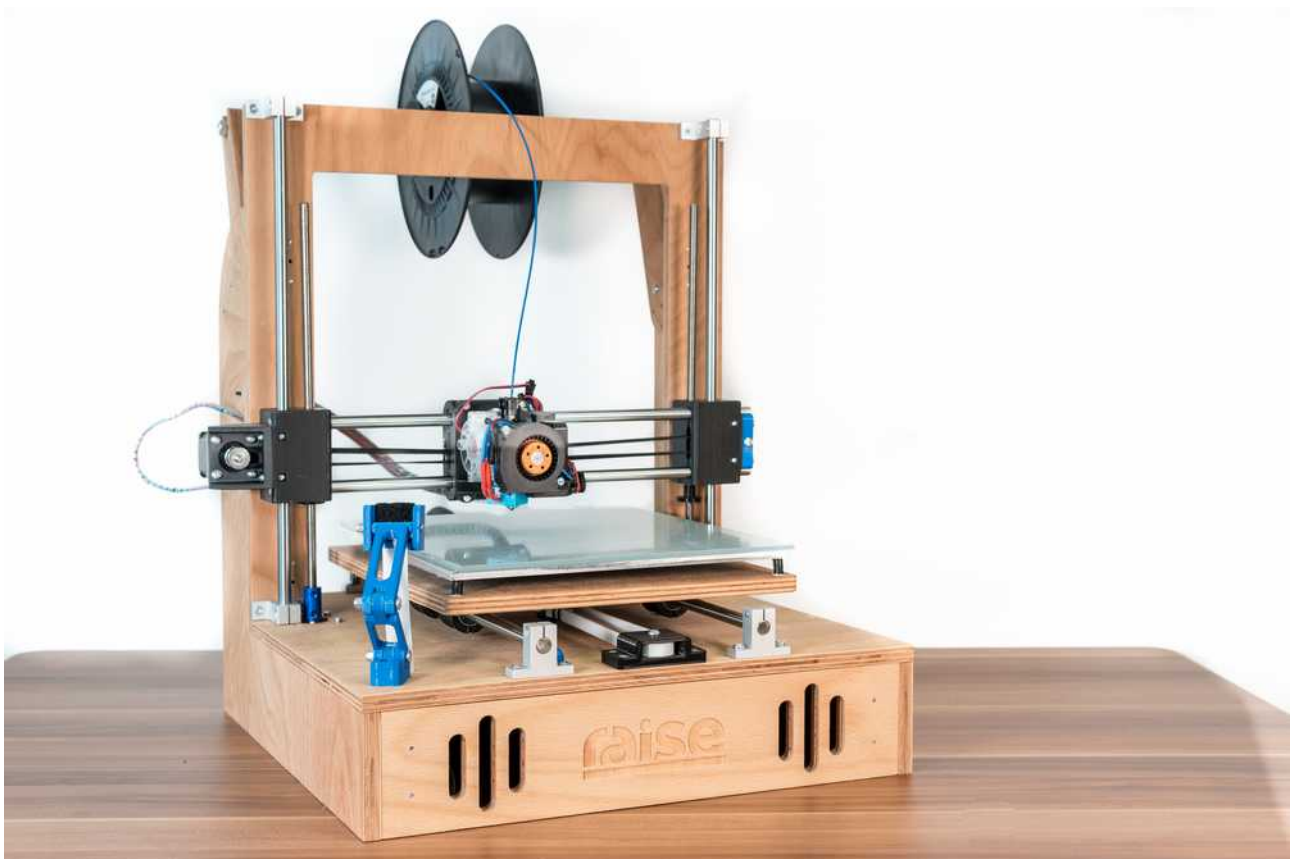

# 1. Introduction

## 1.1. Safety information

The printer has a number of safety circuits, but never leave it unattended.

Do not lift the printer while the power plug is plugged in. There is a risk of electric shock.

Keep the pressure chamber clear. Handling within the installation space can cause injuries.

Never touch the heating components while the printer is switched on, as this may cause burns.

Use suitable fire extinguishers in case of fire to avoid the danger of an electric shock.

Have maintenance work on the electronics and mechanics carried out by a service technician to prevent damage.

The current-carrying components should be connected by a trained electrician (VDE)! The company raise-UAV assumes no liability for damages and injuries resulting from faulty installations.

## 1.2. Lieferumfang

## 1.3. Technical details

Tabelle

## 2. Assembly

### 2.1. Manufacturing the Frame

Beech plywood with a thickness of  $\leq 12\text{mm}$  was used for the frame. The panels have a maximum dimension of 400mm in all directions. A little reserve when milling is to be considered. Milling was done with a 3mm universal double cutter or 3mm diamond cut.

Milling parameters for beech plywood:

300 mm/min at 3mm immersion depth conventional (clockwise)

800W spindle at 30000 revolutions

Panel blanks with 450 x 450mm were used, which enables individual turning of the panels so that during assembly the curvature lies outside and can be pulled against the milled edge.

When drilling the holes (CNC), a circular movement of at least 0.5mm (at 3mm milling cutter) must be observed to ensure chip removal.

The holes should not exceed 3.5mm as these threads are drilled with a 4mm tap.

All 3mm holes in the drawing are therefore provided with an M4 thread which is necessary for the connection with the printed angles.

### 2.2 Post-processing of the plates

Grinding was done with a triangular grinder (depending on availability) to get the surface as smooth as possible for impregnation.

Polyboy wood oil has proved its worth since it cannot ignite itself and offers sufficient protection of the wood without toxic components. It can also be used indoors without the risk of solvents in the room air. Alternatively, the panels can of course also be painted.

### 2.3 Printed parts

All parts can be printed in PLA with a minimum filling of 30%. The Nema14X holder should be made of temperature-resistant materials. In this case Greentec was used which withstands temperatures up to 60°C without any problems. With the larger Nema17 mount, the temperature is expected to be lower, so PLA or better PETG is completely adequate at this point. The Hotendhalter for the Titan Aero or MK8 extruder can also be printed from more thermostable materials.

## 2.4. Frame Assembly

The frame is held together by two types of angles. They compensate and dampen possible distortion in the plywood panels and are easy to produce.

The angles are fixed with M4 x 16 mm screws in the previously cut threads in the plywood panels M4. explosion animation

Start with the two side panels, the base plate, the front and back plates. It is recommended that the installation be carried out on a level ground. When tightening the screws make sure that nothing is distorted. The frame is largely self-aligning. Finally, the portal with any existing curvature is inserted in the direction of the logo and pulled backwards with the portal angles against the side panels.



Abbildung 1: Übersicht



Abbildung 2: Position Angles

## 2.5 Lage der Komponenten

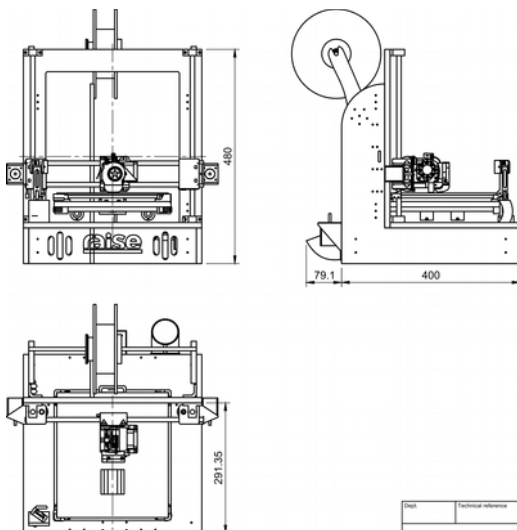



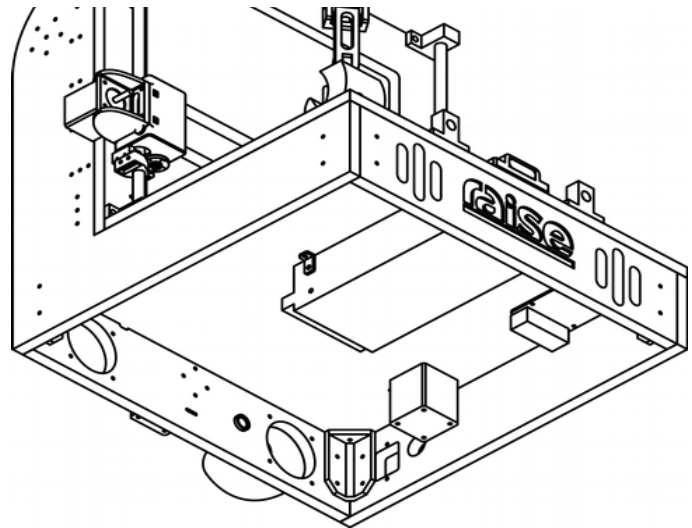
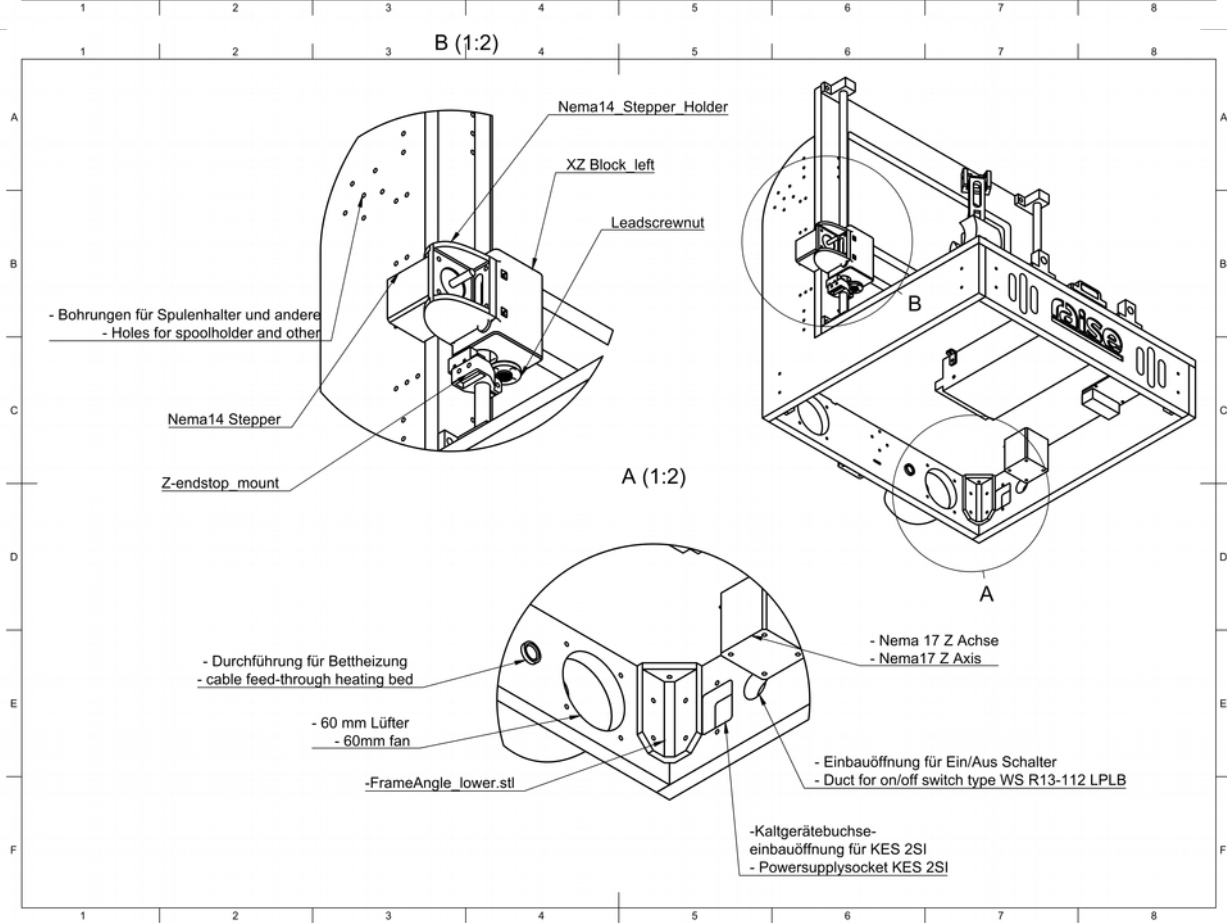
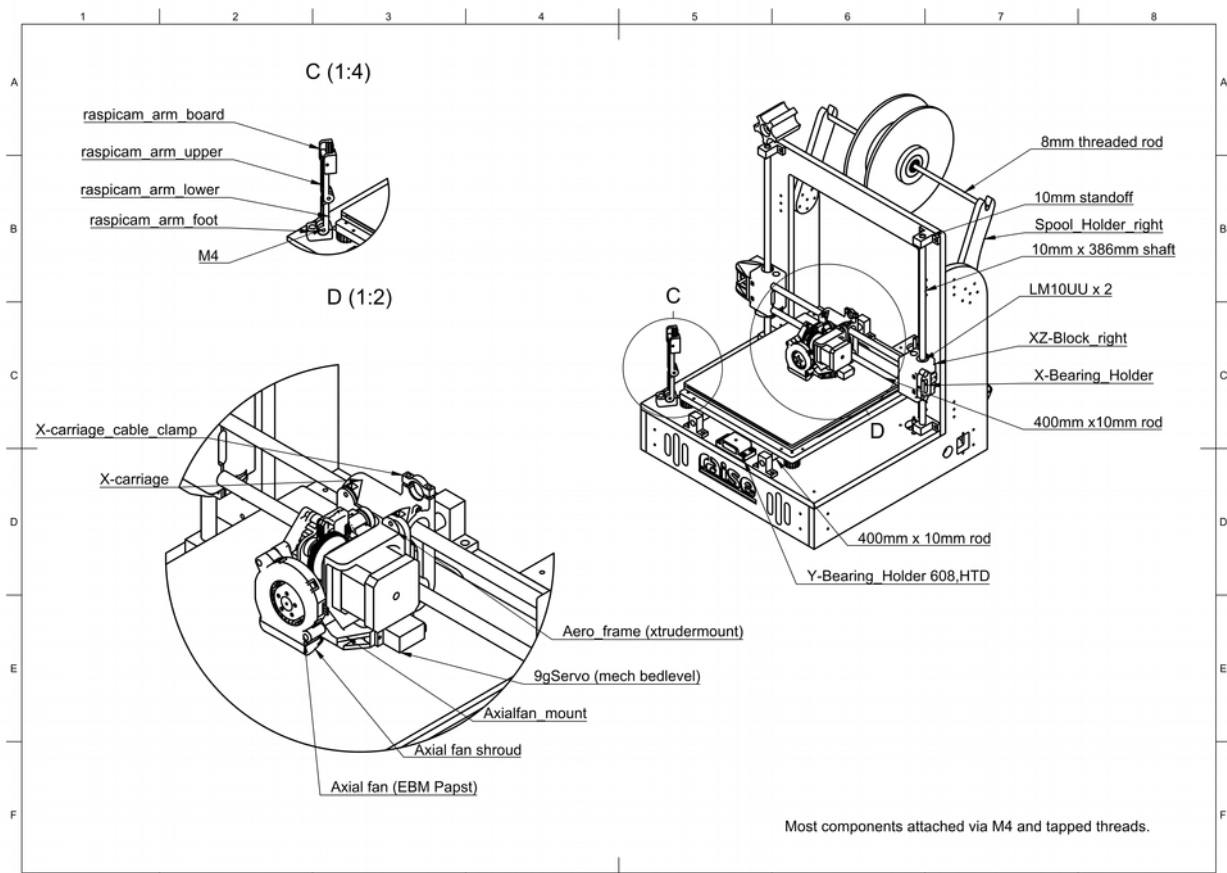





## 1. Einfuehrung

1.1. Sicherheitshinweise

1.2. Lieferumfang

1.3. Technische Details

## 2. Montage des Druckers

2.1. Aufbau des Rahmens

2.2. Installation der Linearmechanik

2.3. Installation der elektronischen Komponenten

2.4. Verkabelung

2.5. Ausrichten des Druckbetts

## 3. Software

3.1. Cura installation

3.2. WLAN Einrichtung

3.3. Koppeln des Druckers mit Cura

## 4. Allgemeiner Workflow

## 5. Support

## 6. Rechtliches